

PRODUCT SPECIFICATION

1.5" a-Si TFT LCD MODULE
MODEL: IPS015B101A Ver:1.6

ROHS

- < ◇ > Preliminary Specification
- < ◆ > Finally Specification

CUSTOMER'S APPROVAL	
CUSTOMER :	
SIGNATURE:	DATE:

APPROVED BY	PM REVIEWED	PD REVIEWED	PREPARED BY

Revision History

Revision	Date	Originator	Detail	Remarks
1.0	2014.10.20		Initial Release	
1.1	2014.10.22		Modify Outline Drawing	P23
1.2	2014.10.24		Modify RGB Interface Timing	P13~14
1.3	2014.11.27	DS	Modify RGB Interface Timing	P14
1.4	2014.12.01	DS	Modify Weight Modify Current Consumption Modify Optical Characteristics	P4 P5 P6
1.5	2015.02.05	HXM	Modify outline drawing	P25
1.6	2015.12.15	TQ	Modify Luminance on TFT Modify Chromaticity Transmissive	P6

Table of Contents

No.	Item	Page
	Modify RGB Interface Timing.....	2
1.	General Description.....	4
2.	Module Parameter.....	4
3.	Absolute Maximum Ratings.....	4
4.	DC Characteristics.....	5
5.	Backlight Characteristic.....	5
5.1.	Backlight Characteristics.....	5
5.2.	Backlighting circuit.....	5
6.	Optical Characteristics.....	6
6.1.	Optical Characteristics.....	6
6.2.	Definition of Response Time.....	6
6.3.	Definition of Contrast Ratio.....	7
6.4.	Definition of Viewing Angles.....	7
6.5.	Definition of Color Appearance.....	8
6.6.	Definition of Surface Luminance, Uniformity and Transmittance.....	8
7.	Block Diagram and Power Supply.....	9
8.	Interface Pins Definition.....	10
9.	AC Characteristics.....	11
9.1.	3-Line SPI System Timing Characteristics.....	11
10.	Timing Chart.....	12
RGB Interface Timing.....	12	
11.	Quality Assurance.....	15
11.1.	Purpose.....	15
11.2.	Standard for Quality Test.....	15
11.3.	Nonconforming Analysis & Disposition.....	15
11.4.	Agreement Items.....	15
11.5.	Standard of the Product Visual Inspection.....	15
11.6.	Inspection Specification.....	16
11.7.	Classification of Defects.....	20
11.8.	Identification/marketing criteria.....	20
11.9.	Packaging.....	20
12.	Reliability Specification.....	21
13.	Precautions and Warranty.....	22
13.1.	Safety.....	22
13.2.	Handling.....	22
13.3.	Storage.....	22
13.4.	Metal Pin (Apply to Products with Metal Pins).....	22
13.5.	Operation.....	23
13.6.	Static Electricity.....	23
13.7.	Limited Warranty.....	23
14.	Packaging.....	24
15.	Outline Drawing.....	25

1. General Description

The specification is a transmissive type color active matrix liquid crystal display (LCD) which uses amorphous thin film transistor (TFT) as switching devices. This product is composed of a TFT-LCD panel, driver IC and a backlight unit.

2. Module Parameter

Features	Details	Unit
Display Size(Diagonal)	1.5"	
LCD type	a-Si TFT	
Display Mode	Transmissive/Normal black	
Resolution	320 RGB x 320	Pixels
View Direction	FULL VIEW	Best Image
Module Outline	31.9 (H) x 36.88 (V) x 2.7(T) (Note1)	mm
Active Area	27.744 (H) x 27.744 (V)	mm
Pixel Size	86.7(H) x 86.7 (V)	um
Pixel Arrangement	RGB Stripe	
Display Colors	65K	
Interface	16-bit RGB + 3-wire SPI Interface	
Driver IC	ILI9488	-
With or without touch panel	Without	
Operating Temperature	-20~70	°C
Storage Temperature	-30~80	°C
Weight	5	g

Note 1: Exclusive hooks, posts, FFC/FPC tail etc.

3. Absolute Maximum Ratings

$V_{SS}=0V, T_a=25^{\circ}C$

Item	Symbol	Min.	Max.	Unit
Supply Voltage	VDD	-0.3	3.3	V
Supply Voltage(Logic)	IOVCC	-0.3	3.3	V
Storage temperature	T _{stg}	-30	+80	°C
Operating temperature	T _{op}	-20	+70	°C

Note 1: If T_a below $50^{\circ}C$, the maximal humidity is 90%RH, if T_a over $50^{\circ}C$, absolute humidity should be less than 60%RH.

Note 2: The response time will be extremely slow when the operating temperature is around $-10^{\circ}C$, and the back ground will become darker at high temperature operating.

4. DC Characteristics

Item	Symbol	Min.	Typ.	Max.	Unit
Supply Voltage	VDD	2.5	2.8	3.3	V
	IOVCC	1.65	1.8	3.3	V
Logic Low input voltage	V _{IL}	GND	-	0.3*IOVCC	V
Logic High input voltage	V _{IH}	0.7* IOVCC	-	IOVCC	V
Logic Low output voltage	V _{OL}	GND	-	0.2* IOVCC	V
Logic High output voltage	V _{OH}	0.8* IOVCC	-	IOVCC	V
Current Consumption Normal white	I _{CC}	-	5	-	mA

5. Backlight Characteristic

5.1. Backlight Characteristics

Item	Symbol	Condition	Min.	Typ.	Max.	Unit
Forward Voltage	V _F	T _a =25 °C, I _F =20mA/LED	2.8	3.2	3.4	V
Forward Current	I _F	T _a =25 °C, V _F =3.2V/LED	-	40	-	mA
Power dissipation	P _d		-	128	-	mW
Uniformity	Avg		80	85	-	%
Drive method	Constant current					
LED Configuration	2 White LEDs in parallel					

5.2. Backlighting circuit

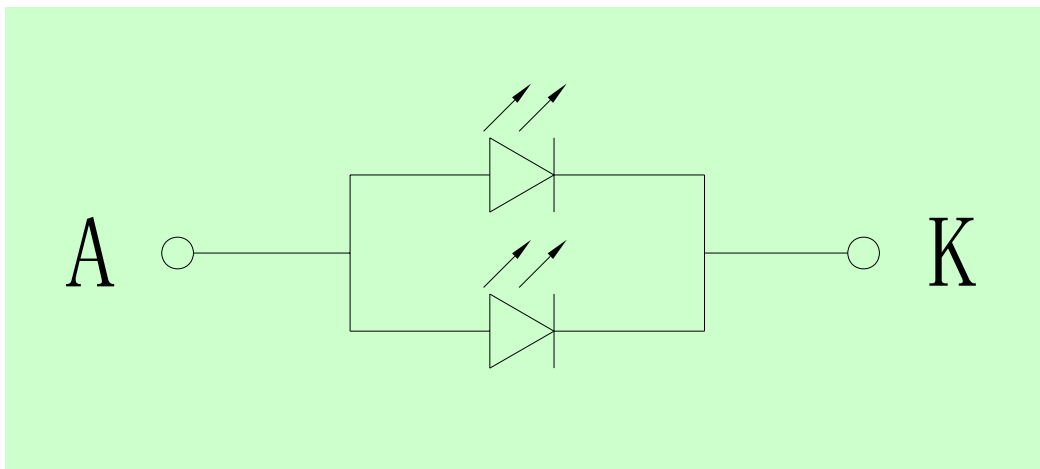

6. Optical Characteristics

6.1. Optical Characteristics

Ta=25°C, VDD=2.8V, TN LC+ Polarizer

	Item	Symbol	Condition	Specification			Unit	
				Min.	Typ.	Max.		
Backlight On (Transmissive Mode)	Luminance on TFT($I_f=20\text{mA/LED}$)	Lv	Normally viewing angle $\theta_x = \phi_y = 0^\circ$	340	430	-	cd/m ²	
	Contrast ratio(See 6.3)	CR		-	900	-		
	Response time (See 6.2)	T _{R+T_F}		-	35	50	ms	
	Chromaticity Transmissive (See 6.5)	Red	X _R	Center CR≥10	0.552	0.602	0.652	
			Y _R		0.271	0.321	0.371	
		Green	X _G		0.265	0.315	0.365	
			Y _G		0.507	0.557	0.607	
		Blue	X _B		0.097	0.147	0.197	
			Y _B		0.054	0.104	0.154	
	White	X _W	0.229	0.279	0.329			
		Y _W	0.273	0.323	0.373			
	Viewing Angle (See 6.4)	Horizontal	θ_{x+}	-	80	-	Deg.	
			θ_{x-}	-	80	-		
Vertical		ϕ_{y+}	-	80	-			
		ϕ_{y-}	-	80	-			
NTSC Ratio(Gamut)				-	50	-	%	

6.2. Definition of Response Time

6.2.1. Normally Black Type (Negative)

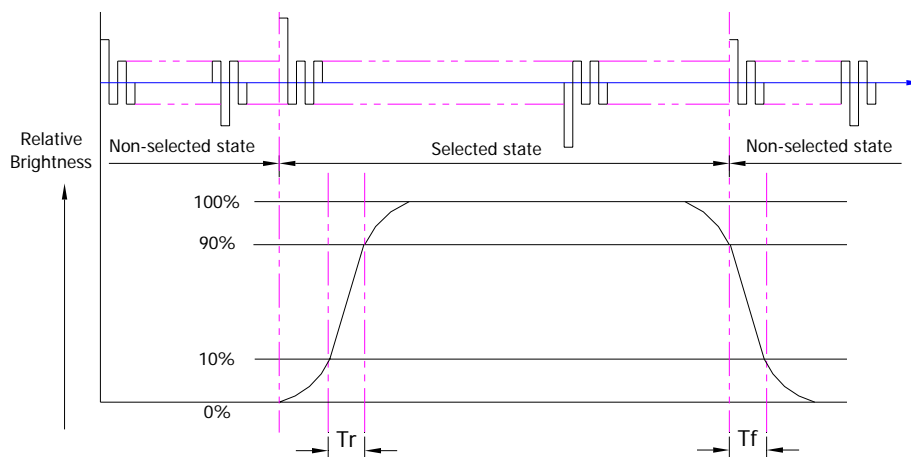

Tr is the time it takes to change from non-selected stage with relative luminance 10% to selected state with relative luminance 90%;

Tf is the time it takes to change from selected state with relative luminance 90% to non-selected state with relative luminance 10%.

Note: Measuring machine: LCD-5100

6.2.2. Normally White Type (Positive)

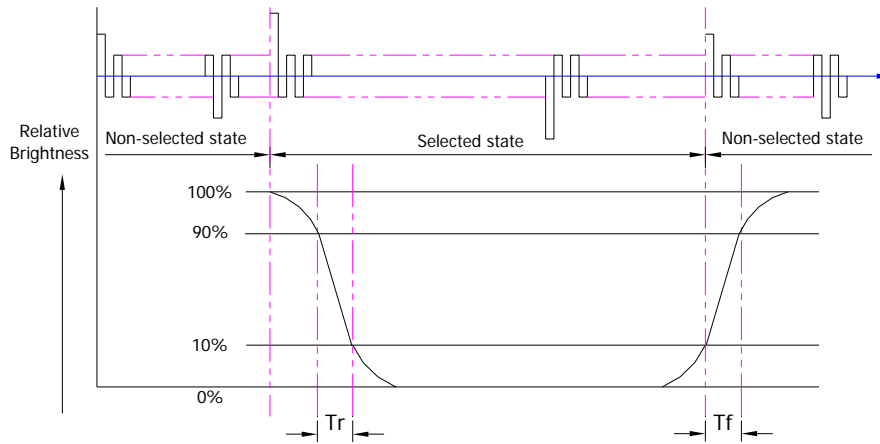

Tr is the time it takes to change from non-selected stage with relative luminance 90% to selected state with relative luminance 10%;

Tf is the time it takes to change from selected state with relative luminance 10% to non-selected state with relative luminance 90%;

Note: Measuring machine: LCD-5100 or EQUI

6.3. Definition of Contrast Ratio

Contrast is measured perpendicular to display surface in reflective and transmissive mode.

The measurement condition is:

Measuring Equipment	Eldim or Equivalent
Measuring Point Diameter	3mm//1mm
Measuring Point Location	Active Area centre point
Test pattern	A: All Pixels white
	B: All Pixel black
Contrast setting	Maximum

Definitions: CR (Contrast) = Luminance of White Pixel / Luminance of Black Pixel

6.4. Definition of Viewing Angles

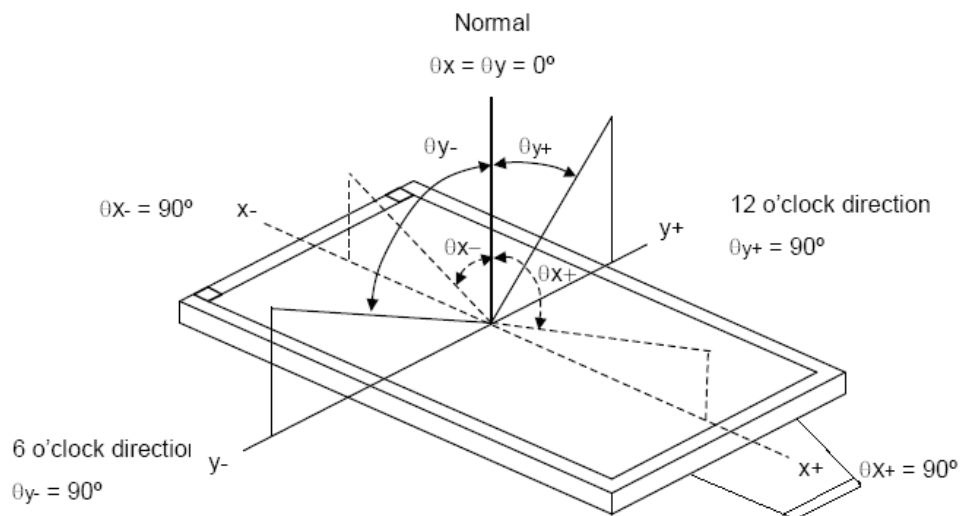

Measuring machine: LCD-5100 or EQUI

6.5. Definition of Color Appearance

R, G, B and W are defined by (x, y) on the IE chromaticity diagram

NTSC=area of RGB triangle/area of NTSC triangleX100%

Measuring picture: Red, Green, Blue and White (Measuring machine: BM-7)

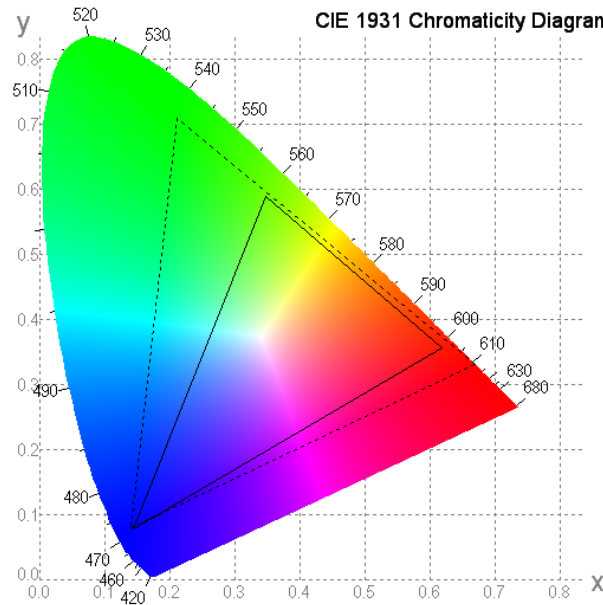

6.6. Definition of Surface Luminance, Uniformity and Transmittance

Using the transmissive mode measurement approach, measure the white screen luminance of the display panel and backlight.

6.6.1. Surface Luminance: $L_v = \text{average} (L_{P1}:L_{P9})$

6.6.2. Uniformity = $\text{Minimal} (L_{P1}:L_{P9}) / \text{Maximal} (L_{P1}:L_{P9}) * 100\%$

6.6.3. Transmittance = $L_v \text{ on LCD} / L_v \text{ on Backlight} * 100\%$

Note: Measuring machine: BM-7

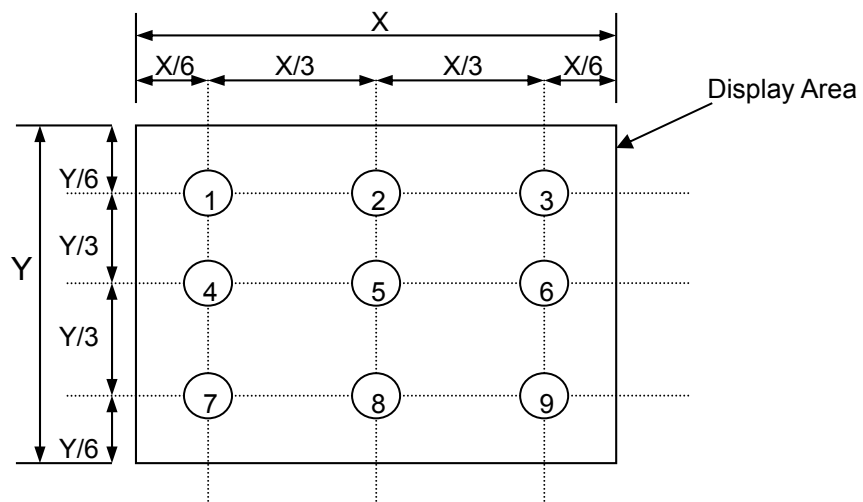

7. Block Diagram and Power Supply

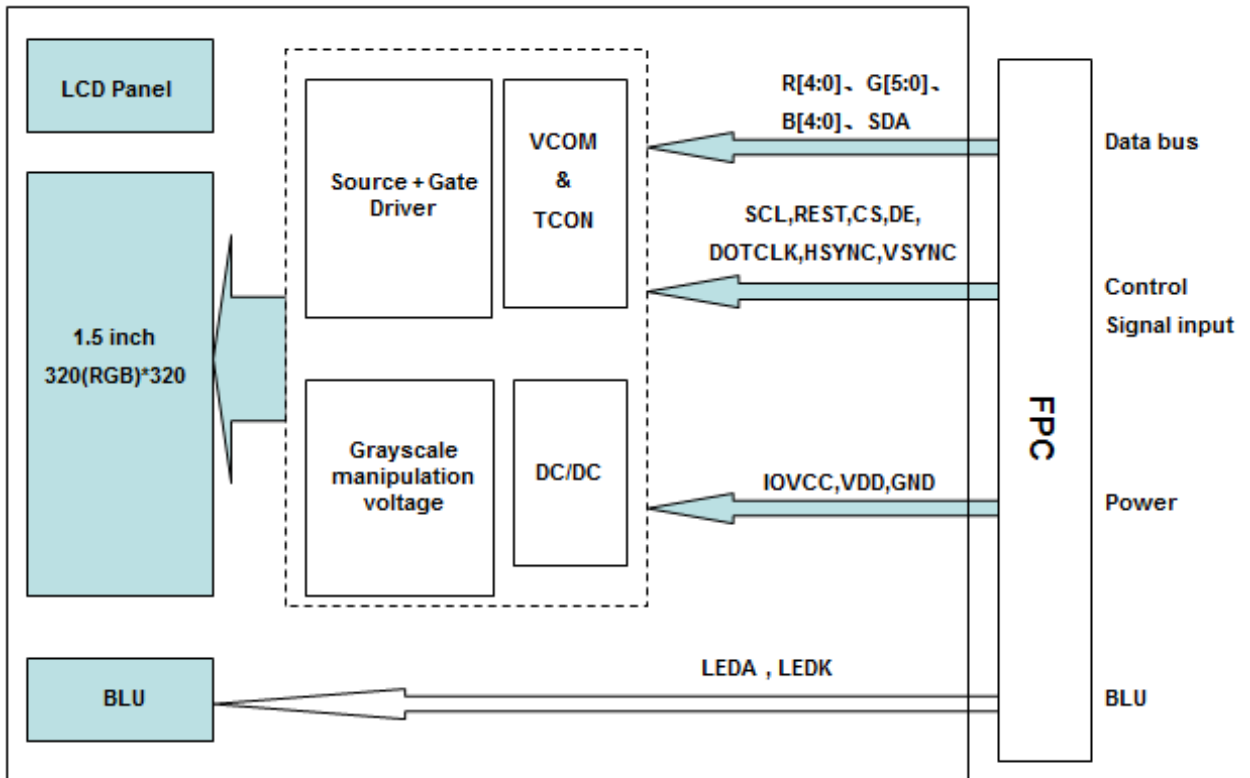

8. Interface Pins Definition

No.	Symbol	Function	Remark
1	GND	Ground.	
2	GND	Ground.	
3	LEDA	LED Anode.	
4	LEDA	LED Anode.	
5	LEDK	LED Cathode.	
6	LEDK	LED Cathode.	
7	LEDK	LED Cathode.	
8	IOVCC	Logic Power supply.	
9	IOVCC	Logic Power supply.	
10	NC	No connection	
11	B0(DB00)	Data bus.	
12	B1(DB01)	Data bus.	
13	B2(DB02)	Data bus.	
14	B3(DB03)	Data bus.	
15	B4(DB04)	Data bus.	
16	G0(DB05))	Data bus.	
17	G1(DB06)	Data bus.	
18	G2(DB07)	Data bus.	
19	G3(DB08)	Data bus.	
20	G4(DB09)	Data bus.	
21	G5(DB10)	Data bus.	
22	NC	No connection	
23	R0(DB11)	Data bus.	
24	R1(DB12)	Data bus.	
25	R2(DB13)	Data bus.	
26	R3(DB14)	Data bus.	
27	R4(DB15)	Data bus.	
28	SDA	Serial data input.	
29	SCL	Serial clock.	
30	REST	Reset signal.	
31	CS	Chip select.	
32	DE	Data enable.	
33	DOTCLK	Pixel Clock signal in RGB I/F mode.	
34	HSYNC	Horizontal sync. Signal in RGB I/F mode.	
35	VSYNC	Vertical sync. Signal in RGB I/F mode.	
36	VDD	Analog Power supply.	
37	VDD	Analog Power supply.	
38	GND	Ground.	
39	GND	Ground.	

9. AC Characteristics

9.1. 3-Line SPI System Timing Characteristics

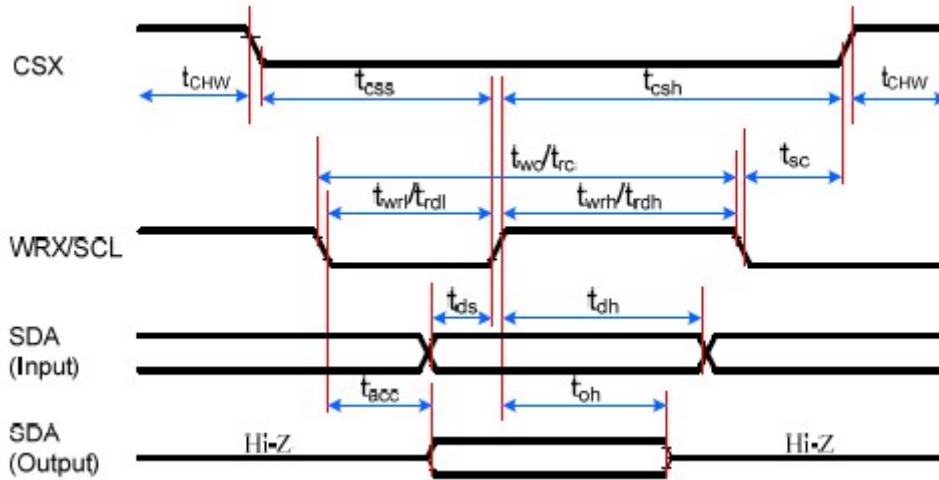

3-pin Serial Interface Characteristics

Signal	Symbol	Parameter	min	max	Unit	Description
CSX	t_{sc}	SCL-CSX	15	-	ns	
	t_{chw}	CSX H Pulse Width	40	-	ns	
	t_{css}	Chip select time (Write)	60	-	ns	
	t_{csh}	Chip select hold time (Read)	65	-	ns	
SCL	t_{wc}	Serial Clock Cycle (Write)	66	-	ns	
	t_{wrh}	SCL H Pulse Width (Write)	15	-	ns	
	t_{wrl}	SCL L Pulse Width (Write)	15	-	ns	
	t_{rc}	Serial Clock Cycle (Read)	150	-	ns	
	t_{rdh}	SCL H Pulse Width (Read)	60	-	ns	
	t_{rdl}	SCL L Pulse Width (Read)	60	-	ns	
SDA/SDI (Input)	t_{ds}	Data setup time (Write)	10	-	ns	
	t_{dh}	Data hold time (Write)	10	-	ns	
SDA/SDO (Output)	t_{acc}	Access time (Read)	10	50	ns	For maximum $C_L=30pF$
	t_{oh}	Output disable time (Read)	15	50	ns	For minimum $C_L=8pF$

Note: $T_a = -30$ to 70 °C, $IOVCC = 1.65V$ to $3.6V$, $V_{CI} = 2.5V$ to $3.6V$, $AGND = DGND = 0V$, $T = 10+/-0.5ns$

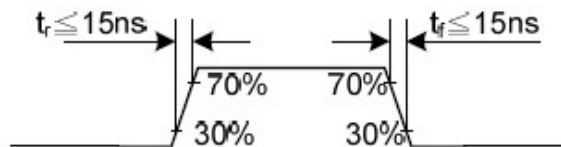

10. Timing Chart

RGB Interface Timing

The timing chart of 16-/18-/24-bit DPI interface mode is illustrated in Figure 1.

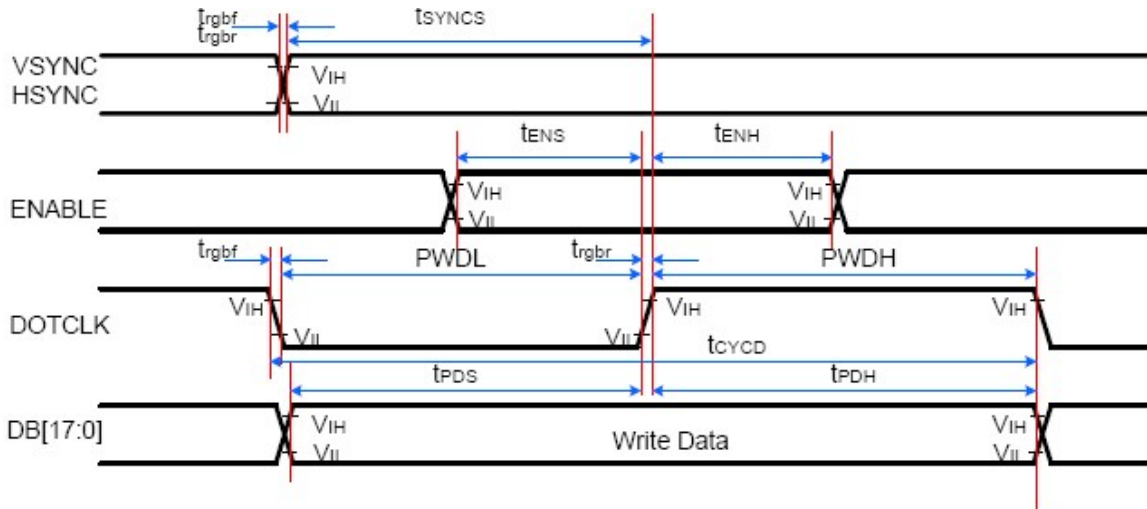

Signal	Symbol	Parameter	min	max	Unit	Description
VSYNC/ HSYNC	t_{SYNCS}	VSYNC/HSYNC setup time	15	-	ns	16-/18-/24-bit bus RGB interface mode
	t_{SYNCH}	VSYNC/HSYNC hold time	15	-	ns	
ENABLE	t_{ENS}	ENABLE setup time	15	-	ns	
	t_{ENH}	ENABLE hold time	15	-	ns	
DB [23:0]	t_{PDS}	Data setup time	15	-	ns	
	t_{PDH}	Data hold time	15	-	ns	
DOTCLK	PWDH	DOTCLK high-level period	20	-	ns	
	PWDL	DOTCLK low-level period	20	-	ns	
	t_{CYCD}	DOTCLK cycle time	50	-	ns	
	t_{rgr}, t_{rgr}	DOTCLK,HSYNC,VSYNC rise/fall time	-	15	ns	

Note: $T_a = -30$ to 70 °C, $IOVCC = 1.65V$ to $3.3V$, $VCI = 2.5V$ to $3.3V$, $AGND = DGND = 0V$

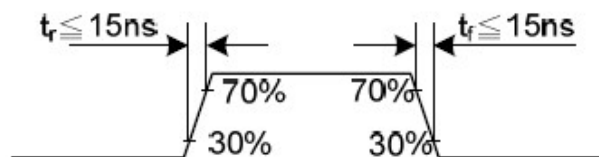

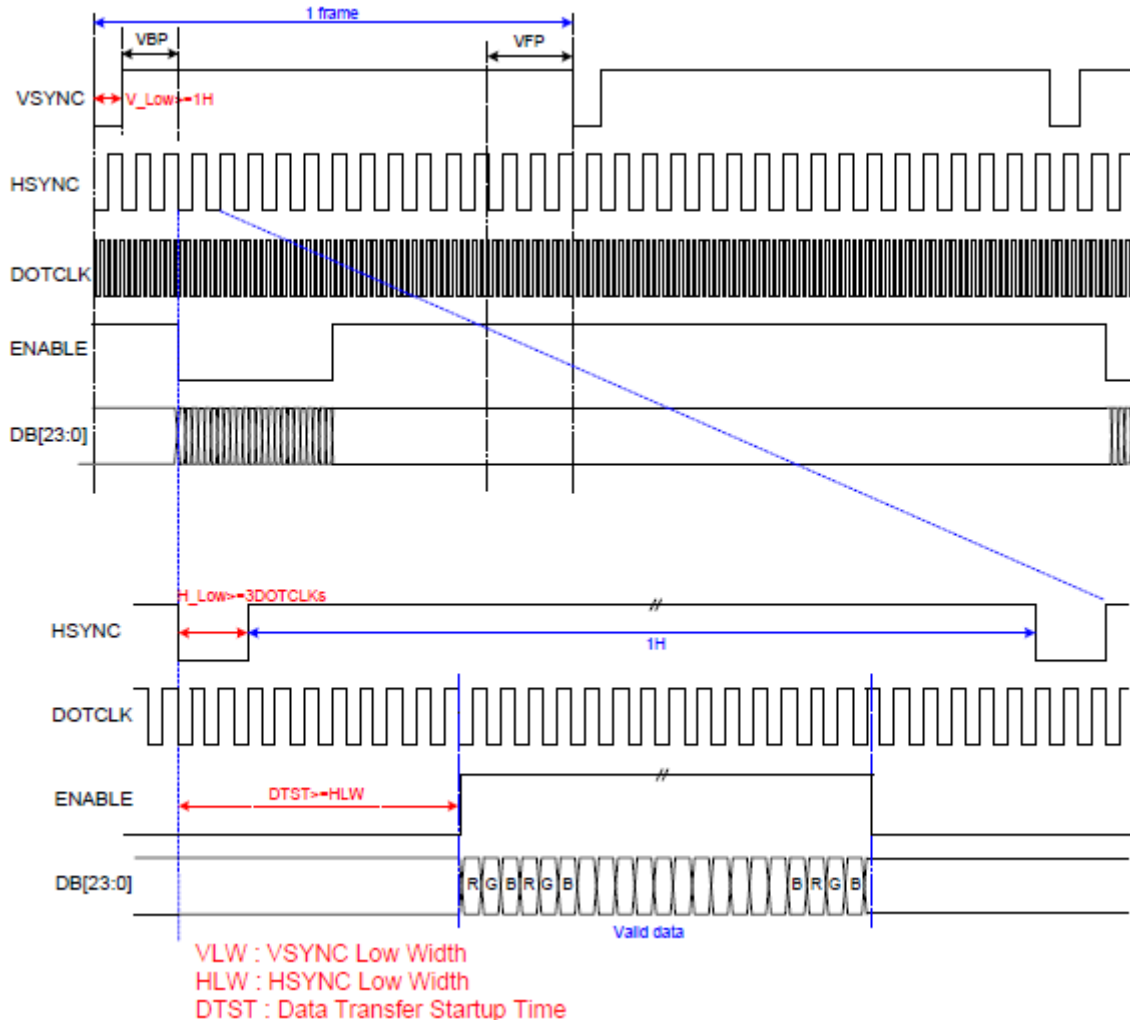

Figure 1: DPI Interface Timing Diagram

Note: VSPL = 0, HSPL = 0, DPL = 0 and EPL = 0 of Interface Mode Control B0h command.

Timing Characteristics

For 320×320 panel

Horizontal input timing

Parameter		Symbol	Value			Unit
			Min.	Typ.	Max.	
Horizontal display area		HACT	320			DCLK
DCLK frequency		fclk	-	9.6	-	MHz
1 Horizontal Line		th	410			DCLK
HSD pulse width	Min.	HLW	TBD			
	Typ.		20			
	Max.		TBD			
HSD Back Porch (Blanking)		HBP	-	70	-	
HSD Front Porch		HFP	-	40	-	

Vertical input timing

Parameter		Symbol	Value			Unit
			Min.	Typ.	Max.	
Vertical display area		VACT	320			H
VSD period time		frame	-	368	-	H
VSD pulse width		V_Low	-	8	-	H
VSD Back Porch (Blanking)		VBP	2	20	-	H
VSD Front Porch		VFP	-	20	-	H

11. Quality Assurance

11.1. Purpose

This standard for Quality Assurance assures the quality of LCD module products supplied to customer.

11.2. Standard for Quality Test

11.2.1 Sampling Plan:

GB2828.1-2012

Single sampling, general inspection level II

11.2.2 Sampling Criteria:

Visual inspection: AQL 1.5%

Electrical functional: AQL 0.65%.

11.2.3 Reliability Test:

Detailed requirement refer to Reliability Test Specification.

11.3. Nonconforming Analysis & Disposition

11.3.1 Nonconforming analysis:

11.3.1.1 Customer should provide overall information of non-conforming sample for their complaints.

11.3.1.2 After receipt of detailed information from customer, the analysis of nonconforming parts usually should be finished in one week.

11.3.1.3 If cannot finish the analysis on time, customer will be notified with the progress status.

11.3.2 Disposition of nonconforming:

11.3.2.1 Non-conforming product over PPM level will be replaced.

11.3.2.2 The cause of non-conformance will be analyzed. Corrective action will be discussed and implemented.

11.4. Agreement Items

Shall negotiate with customer if the following situation occurs:

11.4.1 There is any discrepancy in standard of quality assurance.

11.4.2 Additional requirement to be added in product specification.

11.4.3 Any other special problem.

11.5. Standard of the Product Visual Inspection

11.5.1 Appearance inspection:

11.5.1.1 The inspection must be under illumination about 1000 – 1500 lx, and the distance of view must be at 30cm ± 2cm.

11.5.1.2 The viewing angle should be 45° from the vertical line without reflection light or follows customer's viewing angle specifications.

11.5.1.3 Definition of area: A Zone: Active Area, B Zone: Viewing Area,

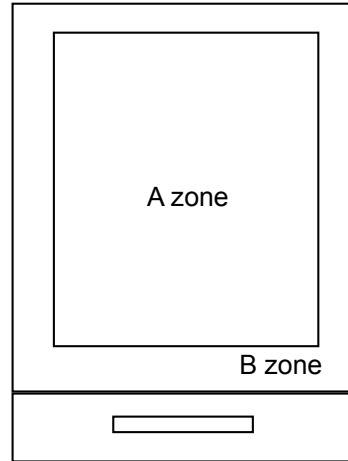
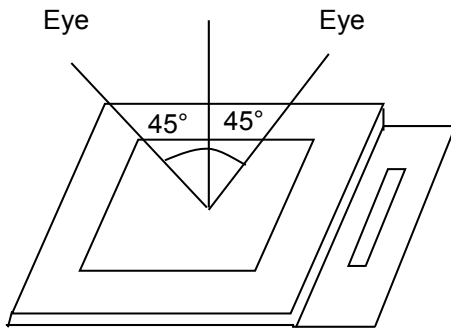

11.5.2 Basic principle:

11.5.2.1 A set of sample to indicate the limit of acceptable quality level must be discussed by both us and customer when there is any dispute happened.

11.5.2.2 New item must be added on time when it is necessary.

11.6. Inspection Specification

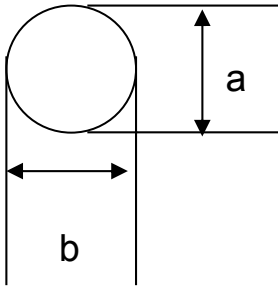
No.	Item	Criteria (Unit: mm)																				
01	Black / White spot Foreign material (Round type) Pinholes Stain Particles inside cell. (Minor defect)	 <p>$\phi = (a + b) / 2$ Distance between 2 defects should more than 3mm apart.</p>	<table border="1"> <thead> <tr> <th>Size \ Area</th> <th>Acc. Qty</th> </tr> </thead> <tbody> <tr> <td>$\phi \leq 0.10$</td> <td>Ignore</td> </tr> <tr> <td>$0.10 < \phi \leq 0.15$</td> <td>2</td> </tr> <tr> <td>$0.15 < \phi \leq 0.25$</td> <td>1</td> </tr> <tr> <td>$0.25 < \phi$</td> <td>0</td> </tr> <tr> <td>Total</td> <td>2 no include $\phi \leq 0.10$</td> </tr> </tbody> </table>	Size \ Area	Acc. Qty	$\phi \leq 0.10$	Ignore	$0.10 < \phi \leq 0.15$	2	$0.15 < \phi \leq 0.25$	1	$0.25 < \phi$	0	Total	2 no include $\phi \leq 0.10$							
Size \ Area	Acc. Qty																					
$\phi \leq 0.10$	Ignore																					
$0.10 < \phi \leq 0.15$	2																					
$0.15 < \phi \leq 0.25$	1																					
$0.25 < \phi$	0																					
Total	2 no include $\phi \leq 0.10$																					
02	Electrical Defect (Minor defect)	<table border="1"> <thead> <tr> <th></th> <th>Display Area</th> <th>Total</th> <th rowspan="3">Note1</th> </tr> </thead> <tbody> <tr> <td>Bright dot</td> <td>0</td> <td>0</td> </tr> <tr> <td>Dark dot</td> <td>$N \leq 2$</td> <td>$N \leq 2$</td> </tr> <tr> <td>Total dot</td> <td>$N \leq 2$</td> <td>$N \leq 2$</td> <td></td> </tr> <tr> <td>Mura</td> <td colspan="2">Not visible through 5% ND filters.</td> <td>Note2</td> </tr> </tbody> </table> <p>Remark: 1. Bright dot caused by scratch and foreign object accords to item 1.</p>				Display Area	Total	Note1	Bright dot	0	0	Dark dot	$N \leq 2$	$N \leq 2$	Total dot	$N \leq 2$	$N \leq 2$		Mura	Not visible through 5% ND filters.		Note2
	Display Area	Total	Note1																			
Bright dot	0	0																				
Dark dot	$N \leq 2$	$N \leq 2$																				
Total dot	$N \leq 2$	$N \leq 2$																				
Mura	Not visible through 5% ND filters.		Note2																			

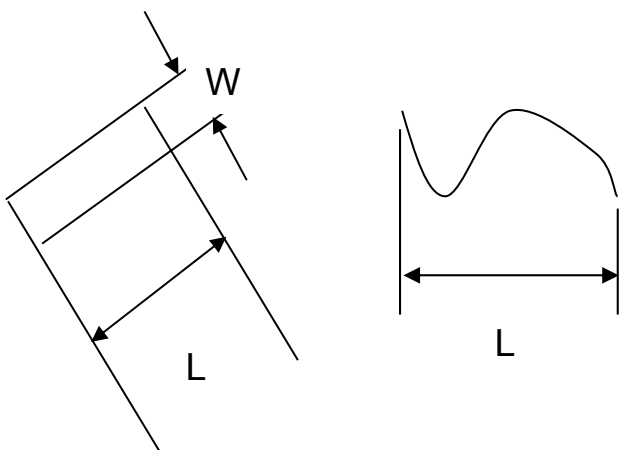
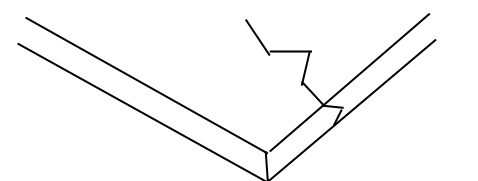
<p>04</p>	<p>Black and White line Scratch Foreign material (Line type) (Minor defect)</p>	 <table border="1" data-bbox="590 784 1212 1097"> <thead> <tr> <th>Length</th> <th>Width</th> <th>Acc. Qty</th> </tr> </thead> <tbody> <tr> <td>/</td> <td>$W \leq 0.03$</td> <td>Ignore</td> </tr> <tr> <td>$L \leq 2.5$</td> <td>$0.03 < W \leq 0.05$</td> <td>3</td> </tr> <tr> <td>$L \leq 2.5$</td> <td>$0.05 < W \leq 0.10$</td> <td>2</td> </tr> <tr> <td>/</td> <td>$0.1 < W$</td> <td>0</td> </tr> <tr> <td colspan="2">Total</td> <td>3</td> </tr> </tbody> </table> <p>Distance between 2 defects should more than 3mm apart. Scratches not viewable through the back of the display are acceptable.</p>	Length	Width	Acc. Qty	/	$W \leq 0.03$	Ignore	$L \leq 2.5$	$0.03 < W \leq 0.05$	3	$L \leq 2.5$	$0.05 < W \leq 0.10$	2	/	$0.1 < W$	0	Total		3
Length	Width	Acc. Qty																		
/	$W \leq 0.03$	Ignore																		
$L \leq 2.5$	$0.03 < W \leq 0.05$	3																		
$L \leq 2.5$	$0.05 < W \leq 0.10$	2																		
/	$0.1 < W$	0																		
Total		3																		
<p>05</p>	<p>Glass Crack (Minor defect)</p>	 <p>Crack is potential to enlarge, any type is not allowed.</p>																		

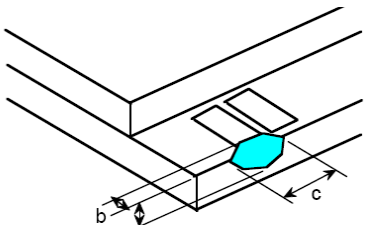
<p>06</p>	<p>Glass Chipping Pad Area: (Minor defect)</p> 	<table border="1" data-bbox="861 1702 1340 1881"> <thead> <tr> <th>Length and Width</th> <th>Acc. Qty</th> </tr> </thead> <tbody> <tr> <td>$c > 3.0, b < 1.0$</td> <td>1</td> </tr> <tr> <td>$c < 3.0, b < 1.0$</td> <td>3</td> </tr> <tr> <td colspan="2">$a < \text{Glass Thickness}$</td> </tr> </tbody> </table>	Length and Width	Acc. Qty	$c > 3.0, b < 1.0$	1	$c < 3.0, b < 1.0$	3	$a < \text{Glass Thickness}$	
Length and Width	Acc. Qty									
$c > 3.0, b < 1.0$	1									
$c < 3.0, b < 1.0$	3									
$a < \text{Glass Thickness}$										

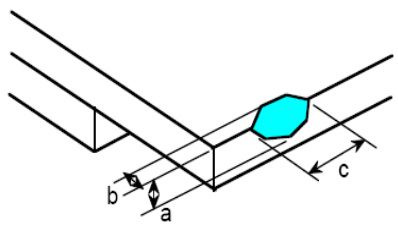
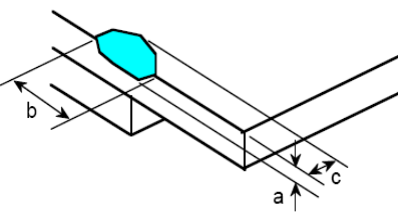
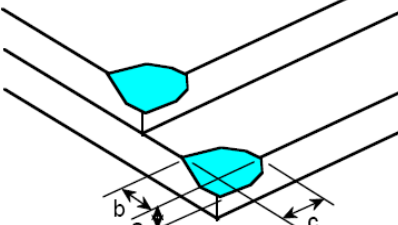
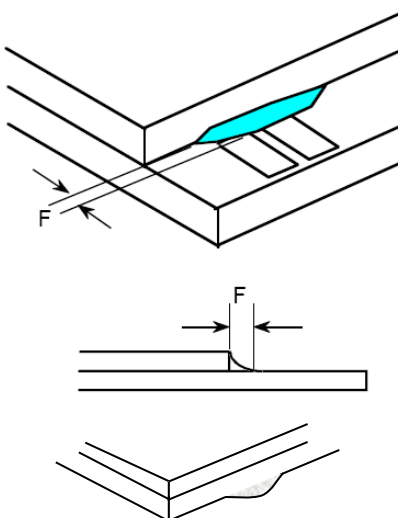
<p>07</p>	<p>Glass Chipping Rear of Pad Area: (Minor defect)</p> 	<table border="1"> <thead> <tr> <th>Length and Width</th> <th>Acc. Qty</th> </tr> </thead> <tbody> <tr> <td>$c > 3.0, b < 1.0$</td> <td>1</td> </tr> <tr> <td>$c < 3.0, b < 1.0$</td> <td>2</td> </tr> <tr> <td>$c < 3.0, b < 0.5$</td> <td>4</td> </tr> <tr> <td colspan="2" style="text-align: center;">$a < \text{Glass Thickness}$</td> </tr> </tbody> </table>	Length and Width	Acc. Qty	$c > 3.0, b < 1.0$	1	$c < 3.0, b < 1.0$	2	$c < 3.0, b < 0.5$	4	$a < \text{Glass Thickness}$	
Length and Width	Acc. Qty											
$c > 3.0, b < 1.0$	1											
$c < 3.0, b < 1.0$	2											
$c < 3.0, b < 0.5$	4											
$a < \text{Glass Thickness}$												
<p>08</p>	<p>Glass Chipping Except Pad Area: (Minor defect)</p> 	<table border="1"> <thead> <tr> <th>Length and Width</th> <th>Acc. Qty</th> </tr> </thead> <tbody> <tr> <td>$c > 3.0, b < 1.0$</td> <td>1</td> </tr> <tr> <td>$c < 3.0, b < 1.0$</td> <td>2</td> </tr> <tr> <td>$c < 3.0, b < 0.5$</td> <td>4</td> </tr> <tr> <td colspan="2" style="text-align: center;">$a < \text{Glass Thickness}$</td> </tr> </tbody> </table>	Length and Width	Acc. Qty	$c > 3.0, b < 1.0$	1	$c < 3.0, b < 1.0$	2	$c < 3.0, b < 0.5$	4	$a < \text{Glass Thickness}$	
Length and Width	Acc. Qty											
$c > 3.0, b < 1.0$	1											
$c < 3.0, b < 1.0$	2											
$c < 3.0, b < 0.5$	4											
$a < \text{Glass Thickness}$												
<p>09</p>	<p>Glass Corner Chipping: (Minor defect)</p> 	<table border="1"> <thead> <tr> <th>Length and Width</th> <th>Acc. Qty</th> </tr> </thead> <tbody> <tr> <td>$c < 3.0, b < 3.0$</td> <td>Ignore</td> </tr> <tr> <td colspan="2" style="text-align: center;">$a < \text{Glass Thickness}$</td> </tr> </tbody> </table>	Length and Width	Acc. Qty	$c < 3.0, b < 3.0$	Ignore	$a < \text{Glass Thickness}$					
Length and Width	Acc. Qty											
$c < 3.0, b < 3.0$	Ignore											
$a < \text{Glass Thickness}$												
<p>10</p>	<p>Glass Burr: (Minor defect)</p> 	<table border="1"> <thead> <tr> <th>Length</th> <th>Acc. Qty</th> </tr> </thead> <tbody> <tr> <td>$F < 1.0$</td> <td>Ignore</td> </tr> </tbody> </table> <p>Glass burr don't affect assemble and module dimension.</p>	Length	Acc. Qty	$F < 1.0$	Ignore						
Length	Acc. Qty											
$F < 1.0$	Ignore											

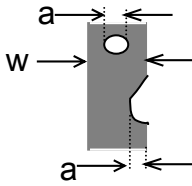
<p>11</p>	<p>FPC Defect: (Minor defect)</p> 	<p>11.1 Dent, pinhole width $a < w/3$. (w: circuitry width.) 11.2 Open circuit is unacceptable. 11.3 No oxidation, contamination and distortion.</p>										
<p>12</p>	<p>Bubble on Polarizer (Minor defect)</p>	<table border="1"> <thead> <tr> <th>Diameter</th> <th>Acc. Qty</th> </tr> </thead> <tbody> <tr> <td>$\varphi \leq 0.20$</td> <td>Ignore</td> </tr> <tr> <td>$0.20 < \varphi \leq 0.30$</td> <td>4</td> </tr> <tr> <td>$0.30 < \varphi \leq 0.50$</td> <td>1</td> </tr> <tr> <td>$0.50 < \varphi$</td> <td>None</td> </tr> </tbody> </table>	Diameter	Acc. Qty	$\varphi \leq 0.20$	Ignore	$0.20 < \varphi \leq 0.30$	4	$0.30 < \varphi \leq 0.50$	1	$0.50 < \varphi$	None
Diameter	Acc. Qty											
$\varphi \leq 0.20$	Ignore											
$0.20 < \varphi \leq 0.30$	4											
$0.30 < \varphi \leq 0.50$	1											
$0.50 < \varphi$	None											
<p>13</p>	<p>Dent on Polarizer (Minor defect)</p>	<table border="1"> <thead> <tr> <th>Diameter</th> <th>Acc. Qty</th> </tr> </thead> <tbody> <tr> <td>$\varphi \leq 0.20$</td> <td>Ignore</td> </tr> <tr> <td>$0.20 < \varphi \leq 0.30$</td> <td>4</td> </tr> <tr> <td>$0.30 < \varphi \leq 0.50$</td> <td>1</td> </tr> <tr> <td>$0.50 < \varphi$</td> <td>None</td> </tr> </tbody> </table>	Diameter	Acc. Qty	$\varphi \leq 0.20$	Ignore	$0.20 < \varphi \leq 0.30$	4	$0.30 < \varphi \leq 0.50$	1	$0.50 < \varphi$	None
Diameter	Acc. Qty											
$\varphi \leq 0.20$	Ignore											
$0.20 < \varphi \leq 0.30$	4											
$0.30 < \varphi \leq 0.50$	1											
$0.50 < \varphi$	None											
<p>14</p>	<p>Bezel</p>	<p>14.1 No rust, distortion on the Bezel. 14.2 No visible fingerprints, stains or other contamination.</p>										
<p>15</p>	<p>Touch Panel</p>	<p>D: Diameter W: width L: length 15.1 Spot: $D < 0.25$ is acceptable $0.25 \leq D \leq 0.4$ 2dots are acceptable and the distance between defects should more than 10 mm. $D > 0.4$ is unacceptable 15.2 Dent: $D > 0.40$ is unacceptable 15.3 Scratch: $W \leq 0.03$, $L \leq 10$ is acceptable, $0.03 < W \leq 0.10$, $L \leq 10$ is acceptable Distance between 2 defects should more than 10 mm. $W > 0.10$ is unacceptable.</p>										
<p>16</p>	<p>PCB</p>	<p>16.1 No distortion or contamination on PCB terminals. 16.2 All components on PCB must same as documented on the BOM/component layout. 16.3 Follow IPC-A-600F.</p>										

17	Soldering	Follow IPC-A-610C standard
18	Electrical Defect (Major defect)	The below defects must be rejected. 18.1 Missing vertical / horizontal segment, 18.2 Abnormal Display. 18.3 No function or no display. 18.4 Current exceeds product specifications. 18.5 LCD viewing angle defect. 18.6 No Backlight. 18.7 Dark Backlight. 18.8 Touch Panel no function.

Remark: LCD Panel Broken shall be rejected. Defect out of LCD viewing area is acceptable.

11.7. Classification of Defects

11.7.1 Visual defects (Except no / wrong label) are treated as minor defect and electrical defect is major.

11.7.2 Two minor defects are equal to one major in lot sampling inspection.

11.8. Identification/marketing criteria

Any unit with illegible / wrong /double or no marking/ label shall be rejected.

11.9. Packaging

11.9.1 There should be no damage of the outside carton box, each packaging box should have one identical label.

11.9.2 Modules inside package box should have compliant mark.

11.9.3 All direct package materials shall offer ESD protection

Note1: Bright dot is defined as the defective area of the dot is larger than 50% of one sub-pixel area.

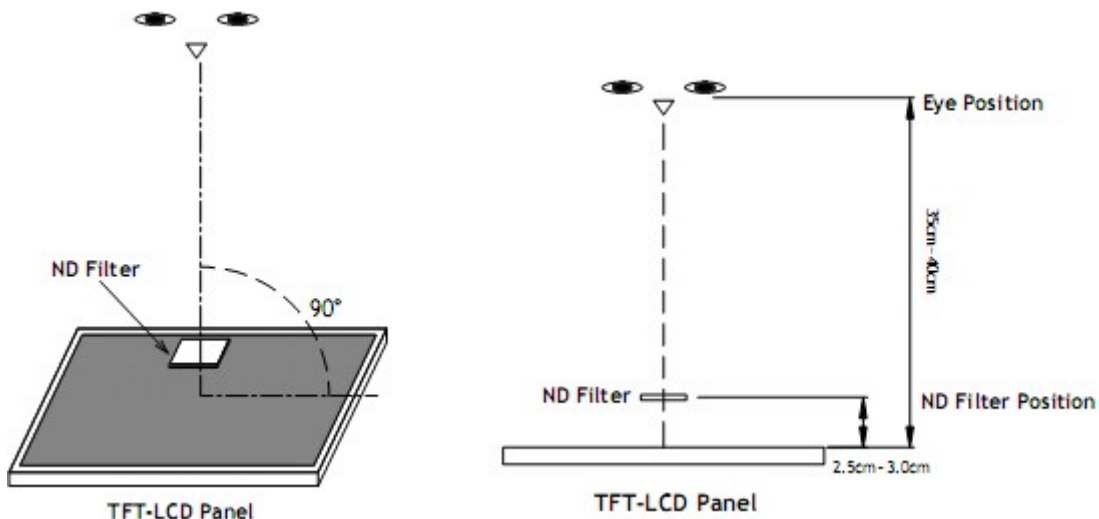

Bright dot: The bright dot size defect at black display pattern. It can be recognized by 2% transparency of filter when the distance between eyes and panel is 350mm ± 50mm.

Dark dot: Cyan, Magenta or Yellow dot size defect at white display pattern. It can be recognized by 5% transparency of filter when the distance between eyes and panel is 350mm ± 50mm.

Note2: Mura on display which appears darker / brighter against background brightness on parts of display area.

12. Reliability Specification

No	Item	Condition	Quantity	Criteria
1	High Temperature Operating	70°C, 96Hrs	2	GB/T2423.2-2008
2	Low Temperature Operating	-20°C, 96Hrs	2	GB/T2423.1-2008
3	High Humidity	50°C, 90%RH, 96Hrs	2	GB/T2423.3-2006
4	High Temperature Storage	80°C, 96Hrs	2	GB/T2423.2-2008
5	Low Temperature Storage	-30°C, 96Hrs	2	GB/T2423.1-2008
6	Thermal Cycling Test	-20°C, 60min~70°C, 60min, 20 cycles.	2	GB/T2423.22-2012
7	Packing vibration	Frequency range:10Hz~50Hz Acceleration of gravity:5G X, Y, Z 30 min for each direction.	2	GB/T5170.14-2009
8	Electrical Static Discharge	Air: ±4KV 150pF/330 Ω 5 times Contact: ±2KV 150pF/330 Ω 5 times	2	GB/T17626.2-2006
9	Drop Test (Packaged)	Height:80 cm,1 corner, 3 edges, 6 surfaces.	2	GB/T2423.8-1995

Note1. No deflection cosmetic and operational function allowable.

Note2. Total current Consumption should be below double of initial value

13. Precautions and Warranty

13.1. Safety

13.1.1 The liquid crystal in the LCD is poisonous. Do not put it in your mouth. If the liquid crystal touches your skin or clothes, wash it off immediately using soap and water.

13.1.2 Since the liquid crystal cells are made of glass, do not apply strong impact on them.
Handle with care.

13.2. Handling

13.2.1 Reverse and use within ratings in order to keep performance and prevent damage.

13.2.2 Do not wipe the polarizer with dry cloth, as it might cause scratch. If the surface of the LCD needs to be cleaned, wipe it swiftly with cotton or other soft cloth soaked with petroleum IPA, do not use other chemicals.

13.3. Storage

13.3.1 Do not store the LCD module beyond the specified temperature ranges.

13.4. Metal Pin (Apply to Products with Metal Pins)

13.4.1 Pins of LCD and Backlight

13.4.1.1 Solder tip can touch and press on the tip of Pin LEAD during the soldering

13.4.1.2 Recommended Soldering Conditions

Solder Type: Sn96.3~94-Ag3.3~4.3-Cu0.4~1.1

Maximum Solder Temperature: 370°C

Maximum Solder Time: 3s at the maximum temperature

Recommended Soldering Temp: 350±20°C

Typical Soldering Time: ≤3s

13.4.1.3 Solder Wetting

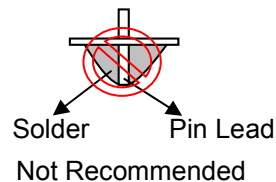
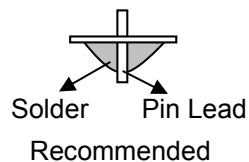

13.4.2 Pins of EL

13.4.2.1 Solder tip can touch and press on the tip of EL leads during soldering.

13.4.2.2 No Solder Paste on the soldering pad on the motherboard is recommended.

13.4.2.3 Recommended Soldering Conditions

Solder type: Nippon Alimit Leadfree SR-34, size 0.5mm

Recommended Solder Temperature: 270~290°C

Typical Soldering Time: ≤2s

Minimum solder distance from EL lamp (body):2.0mm

13.4.2.4 No horizontal press on the EL leads during soldering.

13.4.2.5 180° bend EL leads three times is not allowed.

13.4.2.6 Solder Wetting

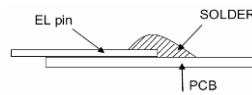

Recommended

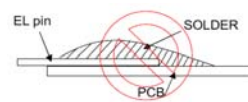

Not Recommended

13.4.2.7 The type of the solder iron:

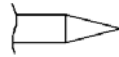

Recommended

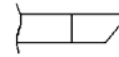

Not Recommended

13.4.2.8 Solder Pad

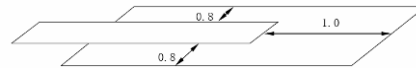

13.5. Operation

- 13.4.1 Do not drive LCD with DC voltage
- 13.4.2 Response time will increase below lower temperature
- 13.4.3 Display may change color with different temperature
- 13.4.4 Mechanical disturbance during operation, such as pressing on the display area, may cause the segments to appear "fractured".

13.6. Static Electricity

- 13.6.1. CMOS LSIs are equipped in this unit, so care must be taken to avoid the electro-static charge, by ground human body, etc.
- 13.6.2. The normal static prevention measures should be observed for work clothes and benches.
- 13.6.3. The module should be kept into anti-static bags or other containers resistant to static for storage.

13.7. Limited Warranty

- 13.7.1 Our warranty liability is limited to repair and/or replacement. We will not be responsible for any consequential loss.
- 13.7.2 If possible, we suggest customer to use up all modules in six months. If the module storage time over twelve months, we suggest that recheck it before the module be used.
- 13.7.3 After the product shipped, any product quality issues must be feedback within three months, otherwise, we will not be responsible for the subsequent or consequential events.

14. Packaging

TBD

15. Outline Drawing

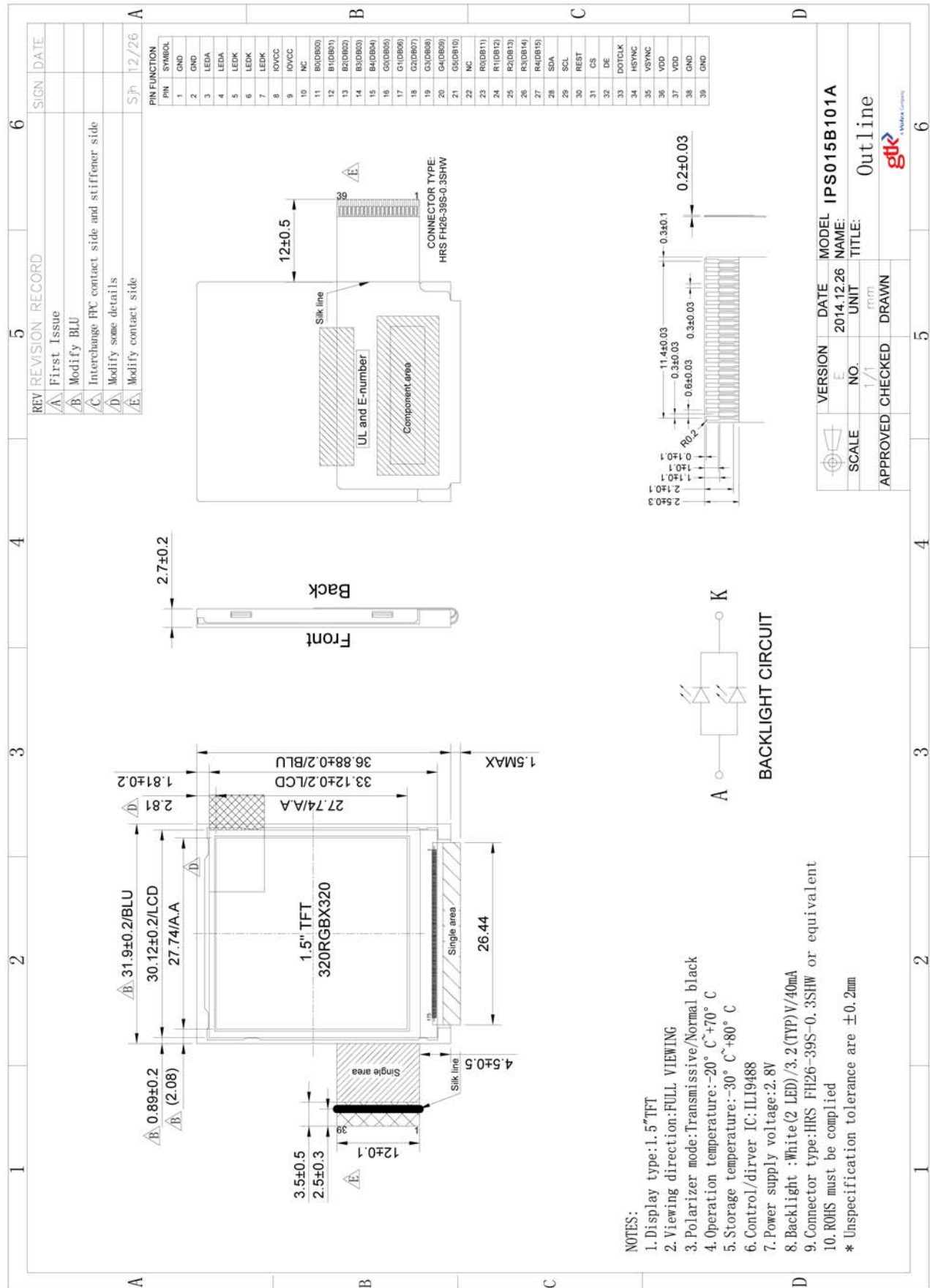

- NOTES:
1. Display type: 1.5" TFT
 2. Viewing direction: FULL VIEWING
 3. Polarizer mode: Transmissive/Normal black
 4. Operation temperature: -20° C ~ +70° C
 5. Storage temperature: -30° C ~ +80° C
 6. Control/driver IC: ILI9488
 7. Power supply voltage: 2.8V
 8. Backlight : White (2 LED) / 3.2(TYP) V / 40mA
 9. Connector type: HRS FH26-39S-0.3SHW or equivalent
 10. ROHS must be complied
- * Unspecification tolerance are ±0.2mm

VERSION	DATE	MODEL
E	2014.12.26	IPS015B101A
SCALE	UNIT	NAME:
1/1	mm	Outline
APPROVED	CHECKED	DRAWN